

System No. F-C-2464

February 09, 2018

F Ratings - 1 Hr

T Ratings - 1 Hr

L Rating At Ambient - Less Than 1 CFM/sq ft

L Rating At 400 F - Less Than 1 CFM/sq ft

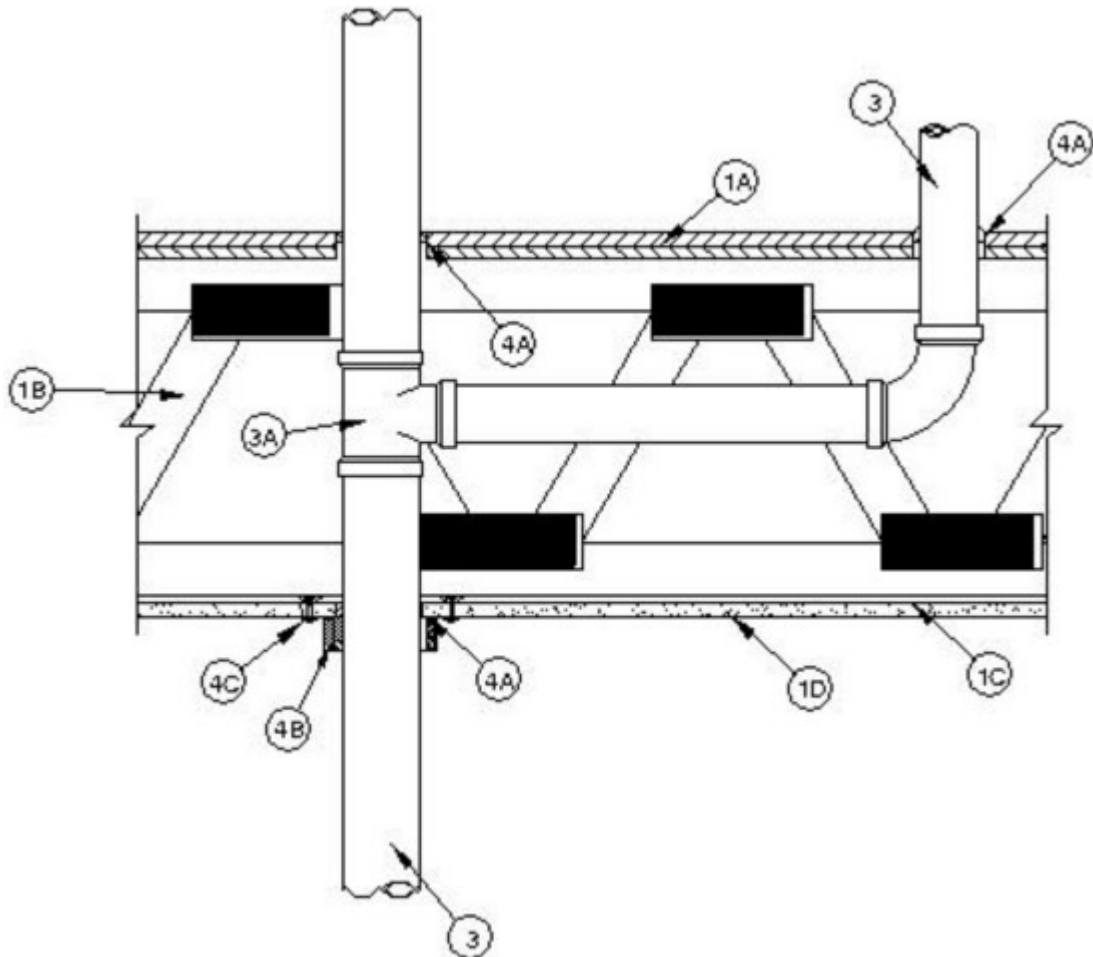

1. Floor-Ceiling Assembly — The 1 hr fire-rated solid or trussed lumber joist floor-ceiling assembly shall be constructed of the materials and in the manner specified in individual L500 Series Floor-Ceiling Designs in the UL Fire Resistance Directory, as summarized below:

- A. Flooring System** — Lumber or plywood subfloor with finish floor of lumber, plywood or **Floor Topping Mixture*** as specified in the individual Floor-Ceiling Design. Max diam of floor opening is 5 in. (127 mm).
- B. Wood Joists** — Nom 2 by 10 in. (51 by 254 mm) lumber joists spaced 16 in. (406 mm) OC with nom 1 by 3 in. (25 by 76 mm) lumber bridging and with ends firestopped. As an alternate to lumber joists, nom 10 in. (254 mm) deep (or deeper) lumber, steel or

combination lumber and steel joists, trusses or **Structural Wood Members*** with bridging as required with ends firestopped.

C. **Furring Channels** — (Not Shown) — Resilient galv steel furring installed perpendicular to wood joists (Item 1B) between gypsum board (Item 1D) and wood joists as required in the individual Floor Ceiling Design.

D. **Gypsum Board*** — Nom 4 ft (1.2 m) wide by 5/8 in. (16 mm) thick as specified in the individual Floor-Ceiling Design. Gypsum board secured to wood joists as specified in the individual Floor-Ceiling Design. Max diam of ceiling opening is 5in. (127mm).

2. **Chase Wall (Optional)** — The through penetrant (Item 3) may be routed through a 1 hr fire-rated single, double or staggered wood stud/gypsum board chase wall constructed of the materials and in the manner specified in individual U300 Series Wall and Partition Designs in the UL Fire Resistance Directory and shall have the following construction details:

CHASE WALL CONFIGURATION A

A. **Studs** — Nom 2 by 6 in. (51 by 152 mm) or double nom 2 by 4 in. (51 by 102 mm) lumber studs.

B. **Sole Plate** — Nom 2 by 6 in. (51 by 152 mm) or parallel 2 by 4 in. (51 by 102 mm) lumber plates, tightly butted. Max diam of opening is 5 in. (127 mm).

C. **Top Plate** — The double top plate shall consist of two nom 2 by 6 in. or two sets of parallel 2 by 4 in. (51 by 102 mm) lumber plates, tightly butted. Max diam of opening is 5 in. (127 mm).

D. **Gypsum Board*** — Thickness, type, number of layers and fasteners shall be as specified in individual Wall and Partition Design.

CHASE WALL CONFIGURATION B

A. **Studs** — Nom 2 by 4 in. (51 by 102 mm), 2 by 6 in. (51 by 152 mm) or double 2 by 4 in. (51 by 102 mm) lumber studs. Nom 2 by 4 in. (51 by 102 mm) studs are allowed for a max 3 in. (76 mm) diameter penetrant.

B. **Sole Plate** — Nom 2 by 4 in. (51 by 102 mm), 2 by 6 in. (51 by 152 mm) or parallel 2 by 4 in. (51 by 102 mm) lumber plates, tightly butted. Plate may be discontinuous over opening, terminating at both sides of periphery of opening. For openings 3 in. (76 mm) diam or less, plate may be continuous with opening cut in plate. Max diam of opening or max length of discontinuity is 4 in. (102 mm).

C. **Top Plate** — The single top plate shall consist of nom 2 by 4 in. (51 by 102 mm), 2 by 6 in. (51 by 152 mm) or parallel 2 by 4 in. (51 by 102 mm) lumber plates, tightly (76 mm) butted. Plate may be discontinuous over opening, terminating at both sides of periphery of opening. For openings 3 in. (76 mm) diam or less, plate may be continuous with opening cut in plate. Max diam of opening or max length of discontinuity is 4 in. (102 mm).

D. **Steel Plate** — For a nom 3 in. (76 mm) diameter penetrant through 2 by 4 in. (51 by 102 mm) lumber plates, two sides of non-continuous lumber plates shall be connected with nom 16 gauge (or heavier) 1-1/2 in. (38 mm) wide steel plate. Steel plates to be sized in length to overlap a min of 4 in. (102 mm) onto each side of the non-continuous

plates and secured with a min of two 1/2 in. (13 mm) long (or longer) No. 8 (or larger) wood screws on each side of each plate.

E. Gypsum Board* — Thickness, type, number of layers and fasteners shall be as specified in individual Wall and Partition Design.

3. Through Penetrants — One nonmetallic pipe to be centered within the firestop system. Diam of opening hole-sawed through flooring (Item 1B) and through both top plates (Item 2C) to be max 1/2 in. (13 mm) larger than the outside diam of pipe. The pipe may be installed with continuous point contact. Pipe to be rigidly supported on both sides of floor-ceiling assembly. The following types nonmetallic pipes may be used:

A. Polyvinyl Chloride (PVC) Pipe — Nom 4 in. (102 mm) diam (or smaller) Schedule 40 cellular or solid core PVC pipe for use in closed (process or supply) or vented (drain, waste, or vent) piping systems.

B. Acrylonitrile Butadiene Styrene (ABS) Pipe — Nom 4 in. (102 mm) diam (or smaller) Schedule 40 cellular or solid core ABS pipe for use in closed (process or supply) or vented (drain, waste or vent) piping systems.

3A. Sanitary Tee (Optional) — The vertical pipe (Item 3) may be provided with a Schedule 40 PVC or ABS sanitary tee above the top plate of the chase wall for connection of a nom 2 in. (51 mm) diam (or smaller) Schedule 40 solid or cellular core PVC or ABS drain pipe, respectively. Drain pipe to run horizontally through the concealed space above the ceiling and penetrate the flooring. Diam of the circular opening in the flooring shall be a max 5/8 in. (16 mm) larger than the diam of the pipe such that a min 0 in. (point contact) to a max 5/8 in. (16 mm) annular space is present between the pipe and the periphery of the opening. The pipe may be installed with continuous point contact.

4. Firestop System — The firestop system shall consist of the following:

A. Fill, Void or Cavity Material* — Sealant — Min 3/4 in. (19 mm) thickness of fill material applied within annulus, flush with top surface of floor or top surface of the sole plate of chase wall assembly (when used). Min 5/8 in. (16 mm) thickness of fill material applied within annulus, flush with the bottom of the gypsum ceiling or bottom surface of lower top plate of chase wall assembly (when used). Additional fill material to be installed such that a min 3/8 in. (10 mm) bead is formed around the through penetrant on the top surface of floor or top surface of the sole plate of chase wall assembly (when used) and the bottom of the gypsum ceiling or bottom surface of lower top plate of chase wall (when used). When the optional sanitary tee is used, min 3/4 in. (19 mm) thickness of fill material applied within annulus between drain pipe and flooring, on top surface of floor. Additional fill material to be installed such that a min 3/8 in. (10 mm) bead is formed around the drain pipe on the top surface of floor. If the through penetrant is installed with continuous point contact, a min 1/2 in. (13 mm) thick bead of fill material shall be applied around outer circumference of through penetrant on top surface of floor and bottom surface of lower top plate.

EVERKEM DIVERSIFIED PRODUCTS INC — Firestop-814+

B. Fill, Void or Cavity Material* — Wrap Strip — Nom 1/4 in. (6 mm) thick intumescent material faced on both sides with a plastic film, supplied in 1 in. (25 mm) wide strips. Two layers of wrap strips are individually wrapped around the through-

penetrant with the ends butted and held in place with masking tape. Butted ends in successive layers shall be offset or aligned. The wrap strips are wrapped around vertical through-penetrant (Item 3) on underside of gypsum board ceiling or bottom surface of lower top plate of chase wall assembly (if used).

EVERKEM DIVERSIFIED PRODUCTS INC — Flame Tech Wrap Strip

C. Steel Collar — Collar fabricated from coils of precut 0.018 in. (0.46 mm) thick (28 MSG) galv sheet steel available from wrap strip manufacturer. Collar shall be nom 1 in. (25 mm) deep with min four 1 in. (25 mm) wide by 2 in. (51 mm) long anchor tabs for attachment to underside of ceiling or bottom surface of lower top plate of chase wall assembly (if used). Retainer tabs, 3/4 in. (19 mm) wide tapering down to 1/4 in. (6 mm) wide and located opposite the anchor tabs, are folded 90 degrees toward through-penetrant surface to maintain the annular space around the through-penetrant and to retain the wrap strips. Steel collar wrapped around wrap strips and vertical through-penetrant (Item 3) with a 1-1/2 in. (38 mm) wide overlap along its perimeter joint and secured together by means of a min 1/2 in. (13 mm) wide by 0.028 in. (0.71 mm) thick stainless steel hose clamp installed at mid-height of the collar. Collar secured to ceiling or bottom surface of lower top plate of chase wall assembly (if used) at each anchor tab with 3/16 in. (4.8 mm) diam by min 3 in. (76 mm) long toggle bolts in conjunction with min 1/4 in. (6 mm) by 1-1/4 in. (32 mm) diam steel fender washers.

*** Indicates such products shall bear the UL or cUL Certification Mark for jurisdictions employing the UL or cUL Certification (such as Canada), respectively.**